

## SILT FENCE MACHINE INSTRUCTIONS:

1. Attach your power unit to main frame; lower arms of a 3-point tractor, or skid loader quick-attach system.
2. For a 3-point system, attach your hoses and fittings to the provided cylinder and install onto top link; or if using a mechanical arm, attach to top link.
3. Main tommy® frame should be up in the air about 30 inches and somewhat level.
4. Position knife/soil-disruptor assembly into the end of the tommy® main frame; use the 9/16 X 3 inch, and 1 X 3 inch, bolts to attach knife assembly to the frame. Which side you insert the bolts does not matter.
5. Attach coultter assembly (large black disc) by first inserting the coultter shank into the frame using 2 – 5/8 X 2 ½ bolts and lock nuts. Insert the round ‘locking collar’ into the side and slot of the coultter assembly, and then slide both pieces over the end and up the coultter shank. Position and tighten ‘locking collar’ as it secures the coultter to the shank.
6. Attach the fabric arm to the left side of the machine, as viewed from the back, with (4) ½ X 1 inch bolts and lock washers threading into the frame itself.
7. Loosen the fabric clamp to remove the plastic wheels. Re-secure the clamp until ready to load a fabric roll.
8. **VERY IMPORTANT:** See the diagram for properly installing the bushing into the plastic wheel, and particularly its position when installed onto the knife assembly. The flange of the bushing must be between the plastic wheel and the support wing holding the wheel. The plastic wheel will fail and operate poorly without the bushing in place. A plastic wheel should perform for at least 100,000 ft. of silt fence, and many contractors have gotten 5 times that use. The machine operates at a slight tilt forward, so the plastic wheel should not be in contact with the soil, or have any stress on it from the soil.
9. **Read the operators manual for complete instructions.** Failure to do so will cause you headaches! Call us if operations don't seem to be going well, as it should be operating smoothly in just a couple of hours as the operator gets some experience.





SILT FENCE MACHINE

“slices through soil & labor costs”

**The tommy® works in many more areas than a trencher!** Side hills, trashy soil and sod, wetlands and swamps, rocky soils and roots.

**No Washouts.** The tommy® slices through the soil, uniquely designed to slightly disrupt soil upward and avoid horizontal compaction. Because soil is only disrupted, and not displaced, its profile is maintained as it’s compacted, insuring greater stability, and greater resistance to wash out.

**The bottom line...** The tommy® works in nearly all conditions—faster, better, and easier than a trencher.

Static Slicing



During Insertion–Disrupted Soil



After Compaction–No Washouts



*Consistent, dependable installations.*

**No Job Too Small or Too Large  
EPA co-sponsored research**

- slicing is 2–4 times faster than trenching
- compaction is directly related to effectiveness
- slicing had no failures
- trenching had multiple failures

**Silt Fence That Works!**



*Retains tons of sediment.*



*Ponds water for sedimentation to occur.*

Trenching Method

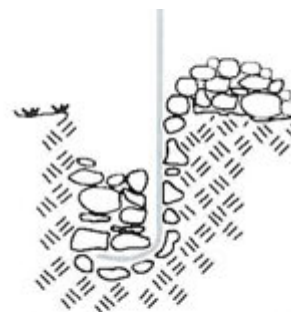

Half the backfill is unavailable. Washouts are common.

## SAFETY HAZARDS

1. While in transport mode, the machine may be above the tractor, thus raising the center-of-gravity of the whole unit, increasing the risk of roll-over on slopes. Operate with extreme caution.
2. The tommy® is hinged vertically to enable turning while in the soil. Shock absorbers are provided to stabilize the machine from jerking movements while in transport. Check their effectiveness regularly, and replace shocks as soon as they appear to be weakening.
3. While in transport, especially across a slope or uneven terrain, the machine can drift to the lower side of the slope, thus increasing the risk of rollover by shifting the tractors center-of-gravity. Operate on slopes with extreme caution and at the lowest possible speed.
4. Follow all safety measures for operation of tractors, especially those associated with operation on a slope. Dual-tires and lor liquid ballast in tires may reduce roll-over risks, but do not substitute for extreme caution.
5. The tommy® while in the ground provides stability to the power unit. Use caution when lifting the machine out of the ground, when you are on a slope. The tommy® could swing downhill and cause an unstable condition or rollover potential. Operate on slopes with extreme caution.
6. Stay clear of the machine while transporting and moving around the construction site. Rough terrain can cause the machine to swing or jerk sideways when it is out of the ground. Walk approximately 6 feet away from the machine when possible. If not, put a hand on the machine while walking to guard against unexpected jerks.
7. Do not put a hand or fingers into the holes of the wheel while machine is moving, nor when the operator is preparing to move it.
8. At times, it may be necessary to gently tug the fabric to keep it from sliding off the wheel. In this case, grab the edge and tug horizontally, away from the holes in the wheel. If the fabric continues to flow off of the vertical wheel, check for other flow restrictions or possibly replace with a new wheel.
9. Do not walk directly behind, nor lean over the inside of the fabric support arm, at any time. There is a shear pin mechanism, which could release suddenly, causing the soil disrupter and wheel to kickback quickly.
10. Use the legs of the machine to store properly. The machine is top-heavy, making blocking or similar means potentially unsafe. Remove auxiliary weights before storing machine on its legs. Also, do not store machine with any pressure on the plastic insertion wheel.
11. Operate the hydraulic cylinder and related equipment per tractor manufacturers specifications.
12. Never stand between the vertical hinged sections of the machine. Do not put any body parts between the vertical hinged sections.
13. Always prepare the vehicle route prior to the installation operations. Clear debris and notify other workers in the area. If operating a skid-steer with the tommy®, utilize another person to watch the direction of travel and to keep others safely away.
14. Do not allow anyone to ride on the machine at any time.



## Devon Distributing Corporation

3718 SW Court Ave. • Ankeny, Iowa 50023 • 1-800-965-4665 • 515-515-645-9699

### PATENT TECHNOLOGY RIGHTS

The “tommy” silt fence machine and the installation process is patented under the United States Letters Patent number 5,915,878. Devon Distributing Corporation owns this patent which protects against the construction, use, or sale of a silt fence machine infringing on this patented process.

It is illegal and an infringement to patent rights to build a machine using this process, even **for your own use** and not for sale to others. Over \$1 million has been invested in bringing this exceptional technology to our industry.

Devon Distributing Corporation offers rewards of up to \$5,000.00 for confidential information leading to payments by an infringer to Carpenter for the construction, use, or sale of a silt fence machine.

#### PARTS LIST

PART #	PART
10	SKID LOADER ADAPTER PLATE
11	WHEEL
12	1/2" FLANGED BUSHING/BOLD
13	HARDENED STEEL POINT
14	FABRIC KNIFE
15	PRESSURE PLATE & SPRING ASSY
16	HINGED WING
17	8" STROKE HYDRAULIC CYLINDER
18	WING CLAMP
19	12" OFFSET ASSEMBLY
20	HEAVY DUTY AIR SHOCKS
21	WEIGHTS - 75LBS EA
22	COULTER ASSEMBLY
23	COULTER SUPPORT POST
24	COULTER DISC ONLY
25	COMPLETE KNIFE ASSY (RTN ORIG)
26	FRONT PLATE
27	COULTER COLLAR
28	SILT FENCE THAT WORKS MANUAL
29	tommy® SILT FENCE MACHINE MANUAL
30	INNER BEARING PKG
31	400 MEASURING WHEEL

The tommy® can carry approx. 3,000 LF of STD weight silt fence material. One of the most economical ways to purchase rolls of silt fence is to purchase partial master rolls to avoid re-rolling charges. (partial master rolls are obtained from manufactures of pre-fabricated silt fence or possibly your local distributor)

*Please call Devon Distributing Corporation with any questions about the availability of parts or prices.*



## IMPORTANT ASSEMBLY NOTICE

Your tommy<sup>®</sup> comes with a hydraulic cylinder to facilitate faster penetration into the soil. All tractors vary as to their 3-point design and construction. The hydraulic cylinder may have to be modified to facilitate the most efficient operation. The cylinder stub is provided to work on many category 2 tractors. Extra holes are provided for the stub to be shortened for category 1 tractors.

Proper length of the cylinder stub is determined by attaching the tommy<sup>®</sup> to the tractor by the lower arms only, carefully raising the lower arms of the 3-point and simultaneously propping the tommy<sup>®</sup> up (possibly setting the point on a sturdy block, or holding the rear of the machine up with another loader) where the frame is parallel with the lower arms of your 3-point. Your hydraulic cylinder should be completely closed and the ram attached to the tommy<sup>®</sup>. Adjust the cylinder (shortening the stub if necessary) to reach the top link catch on the tractor. A small variation of an inch or two may not matter. We can not give you a formula or measurement because the position of the top link varies so much on every tractor style.

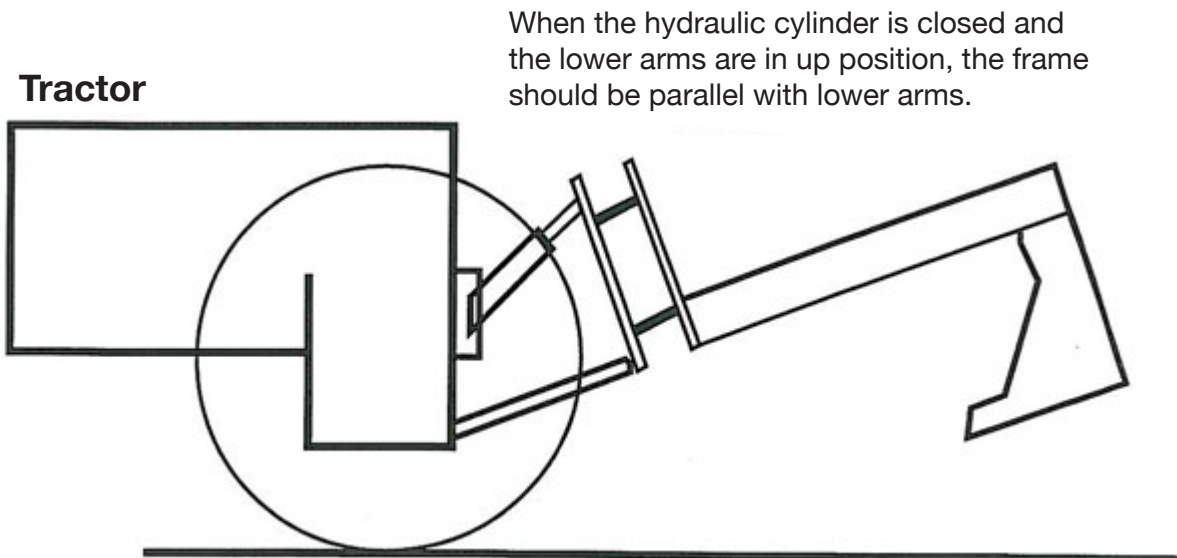

We send hydraulic cylinders out with a 8-inch base stub drilled with two holes. If you have a category 2 tractor, this base stub should be the approximate length that you need. If you have a category 1 tractor, you may have to shorten the base stub and use the lower hole for attachment.

## VIEW FROM BACK OF MACHINE

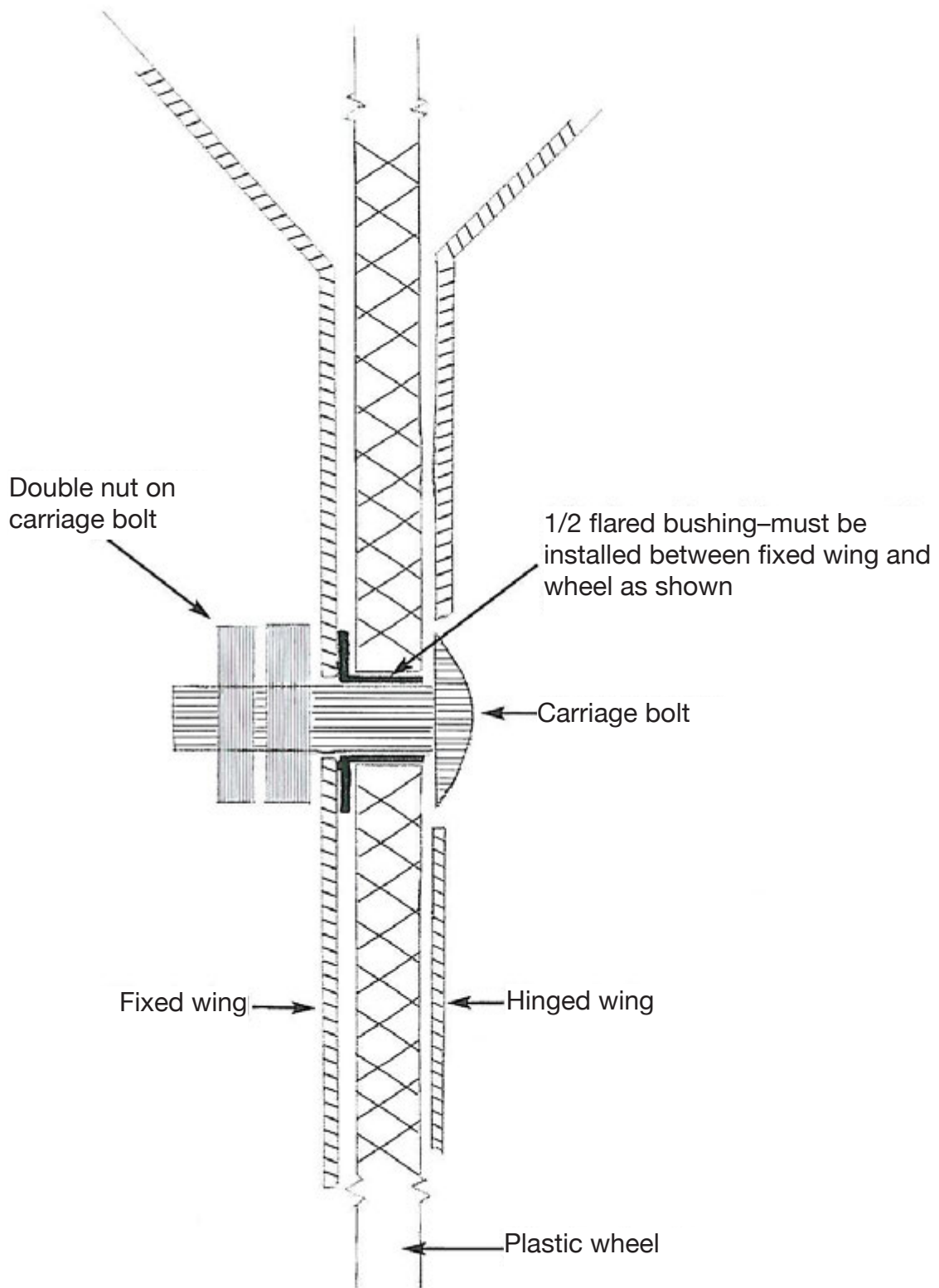

## THE TOP-LINK CYLINDER

The top-link cylinder increases the angle of attack for quicker penetration into the soil, and then levels the tommy<sup>®</sup> out for proper operation. **It does not exert down pressure to push the tommy<sup>®</sup> into the soil.** The point of the soil disrupter helps pull the tommy<sup>®</sup> into the ground and if the frame of the tommy<sup>®</sup> is maintained at a level or a slightly forward angle, the point constantly pulls the tommy<sup>®</sup> downward into the soil as you progress. **See Fig. 5 below.**

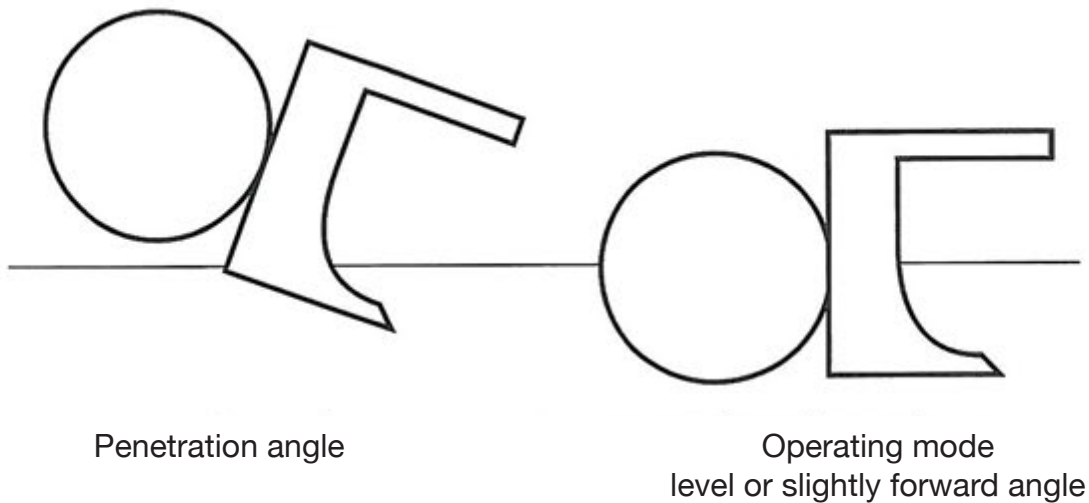

Fig. 5

## GETTING STARTED

The tommy® is available for standard 36" x 1500' to 2500' rolls of silt fence, but it can be easily adapted for smaller and larger rolls. The roll fits over the pipe with the **top of the silt fence material (if there is a top and bottom) positioned away from the arm** of the tommy®. The plate and spring come attached for your convenience. Minimal tension is recommended to restrict the roll from free-wheeling. For very large rolls it might unroll easier if the fabric is coming off the back of the roll rather than the front of the roll.

To thread the fabric through the machine, put your fingers through a hole in the wheel near the top, clasp the bottom of the fabric so that approximately 6" is behind the wheel, and pull the fabric down around the outside of the wheel and through the machine so that the flap on the inside of the wheel is approximately 6" long and the balance of the fabric is on the side nearest you. **See Fig. 4 below.**

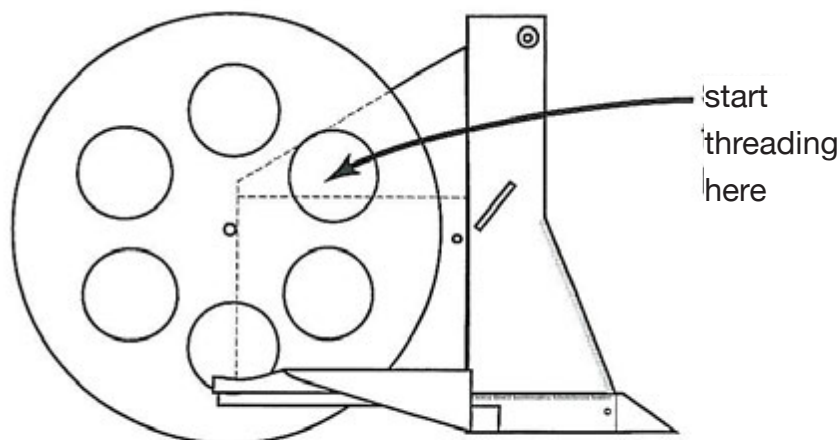

Fig. 4

Once you get more proficient it is not necessary to open the hinged wing to pull the fabric through. After the fabric is threaded out the back, it is a good idea to check the fabrics' position in relation to the wheel, so that the flap is approximately 6" long on the inside of the wheel. **The position of the fabric on the front edge of the wheel is critical.** You must position the 6" flap as described and shown to insure proper installation and operation of the tommy®. Be very careful to avoid pinching or binding the fabric when closing the winged panel.



## HOW DOES IT WORK

The tommy® works on a 3-point hitch system comprised of a soil disrupter that slices thinly through the soil 8-12" deep, and an apparatus for inserting silt fence fabric. The soil disrupter utilizes a chisel type horizontal point to disrupt soil upward causing minimal displacement and minimal horizontal compaction, thus creating an optimum soil condition for future mechanical compaction.

The apparatus is primarily comprised of a ground-driven vertical wheel, positioned between two narrow parallel panels, acting as a moving pivot point where the horizontal silt fence is converted to a vertical position between the panels. In this dynamic operation silt fence is simultaneously pulled off the roll by the ground-driven vertical wheel, funneled into the apparatus, converted to a vertical position between the panels, and inserted into the soil being held open by the panels. As the machine progresses, soil collapses onto the silt fence, thus securing silt fence in the desired position. **See Fig. 1 below.**

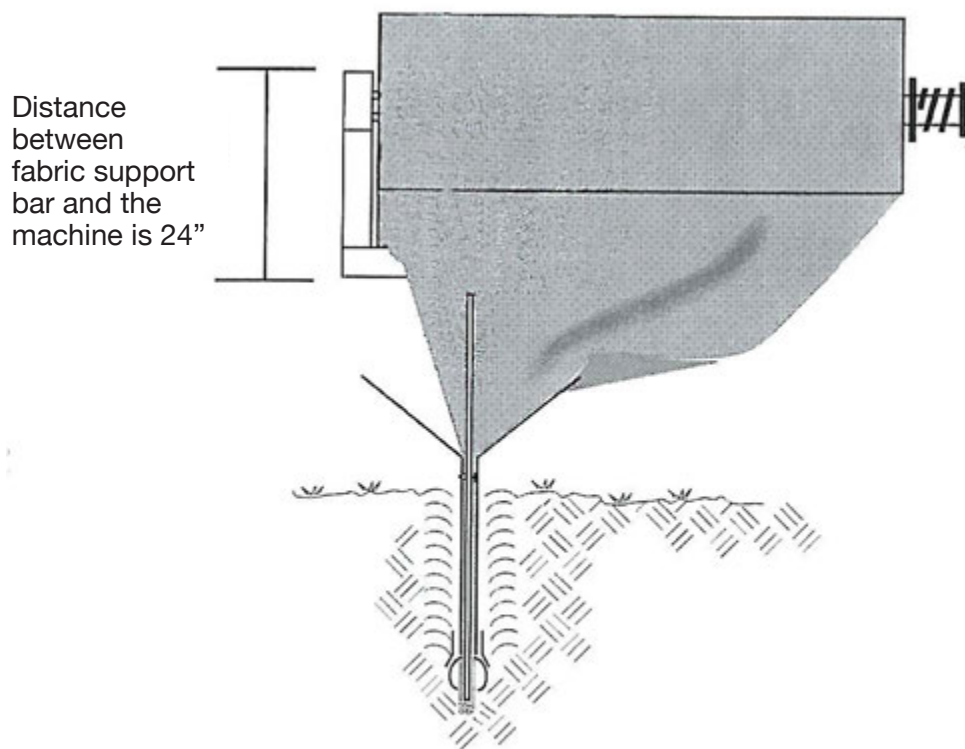

Fig. 1

The silt fence material is converted to the vertical position by the wheel engaging the horizontal silt fence fabric perpendicularly and causing it to fold as it flows between the panels and pivots against the wheel. The fabric maintains the same position in the soil, one flap of the fold being approximately 6" long, with the balance of the silt fence as the other flap. **See Fig. 2 below.**

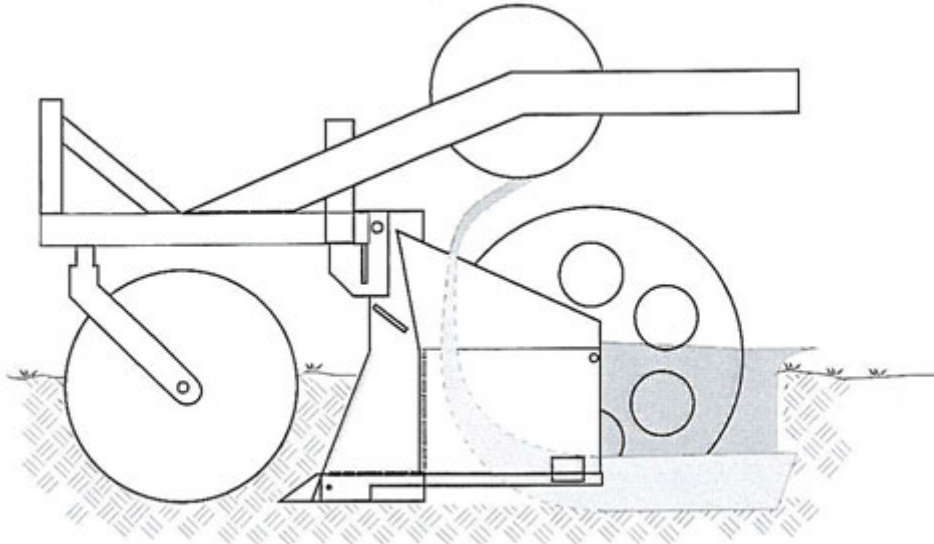
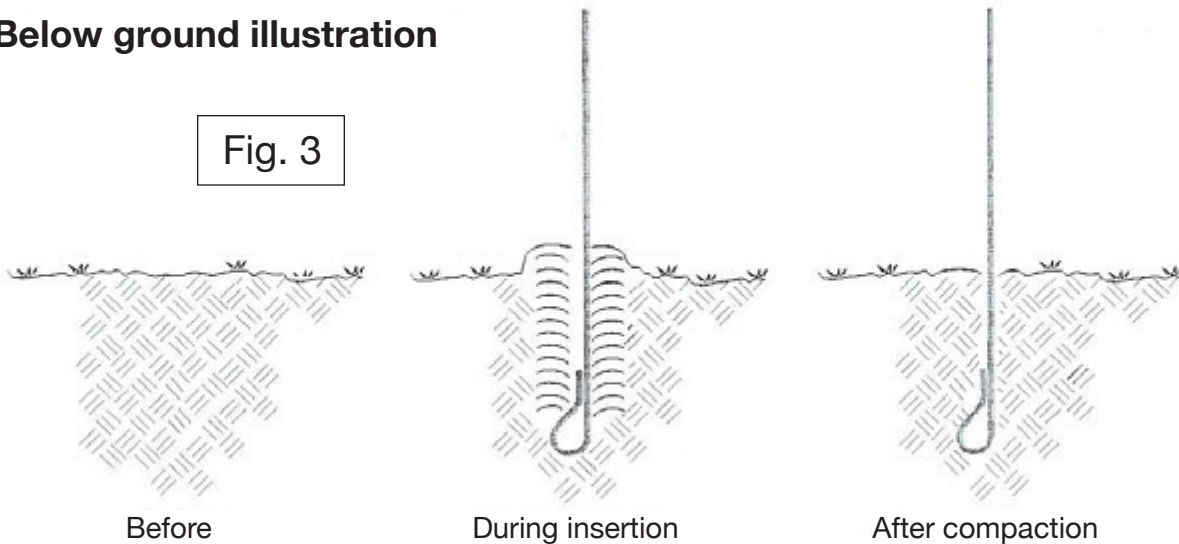

Fig. 2

Minimal soil disruption creates an optimum condition for mechanical compaction, which in turn stabilizes the soil against washout under the silt fence. Disrupting soil upward also reduces horizontal compaction. Horizontal compaction would not allow the soil to fall back onto the fabric nor secure the fabric tightly in the soil. **See Fig. 3 below.**

### Below ground illustration

Fig. 3



## CONTROL THE tommy® WITH THE LOWER ARMS OF THE 3-POINT HITCH

**The tractor operator actually controls the operation of the tommy® in the ground by manipulating the lower arms of the 3-point hitch.** With the point pulling the tommy® downward, the arms are utilized to manage the depth of the tommy® in the soil. As the terrain or compacted status of the soil changes, the operator manipulates the tommy® by slightly raising or lowering the lower arms, attempting to maintain a consistent depth.

As you will learn, manipulating the tommy® slightly does not directly alter the silt fence depth significantly or impair the quality of the installation. If the tommy® does rise out of the soil too much, the crew may have to tuck the silt fence in manually, or dig it in to proper depth.

## INSTALLATION WITH A TRACTOR

**Before starting out, plan your installation route,** clear any major debris, and avoid or level out any major soil variations which would decrease your installation effectiveness. Large clumps of soil and deep rills cause the rear tractor wheel to rise and simultaneously pulls the tommy® out of the soil, which in turn may hinder the installation.

To start, drop the lower arms of the 3-point and retract the top cylinder completely to achieve the maximum penetration angle, and begin pulling forward in your lowest gear. Low gear provides time for the operator to react before a problem arises, thus maintaining a quality installation.

As the tommy® pulls itself into the soil, extend the top cylinder to level out the frame of the tommy®. When you have achieved the desired depth, just below the wing clamp, begin to raise the lower arms to adjust and hold the tommy® in a level position. **The lower arms are the main control for proper depth of fabric placement after the tommy® is leveled out.**

The tommy® is designed to begin feeding out when the wheel, which extends below the soil disrupter, engages the soil with downward pressure. The goal is to get the point into the ground 6-8" as soon as possible, and then level out the tommy® to begin installation.

At the end of your installation, continue past a short distance, stop, and lift the tommy® out of the soil enough for your support person to cut the fabric free, which leaves the fabric in the machine in proper position to start the next installation. Many distributors have specialty cutters for silt fence which makes the job much easier.

## CHECK INSTALLATION BEFORE COMPACTING

The operator needs to survey the installation **before** compacting the soil against the silt fence, to confirm proper installation. Have the support person walk along and check the fabric for proper consistent height. It is easier and faster to fix a small area when the soil is loose rather than when compacted. J-hooks and tight curves are especially sensitive because they are often installed in high pressure areas. **Proper compaction and adequate depth are critical to the successful operation of the silt fence.**

## IMPORTANCE OF PROPER COMPACTION

Insufficient compaction can allow water that has dammed up behind the silt fence to develop a channel underneath the fence and flow up on the downside of the silt fence. We recommend having your loader bucket full of soil and **driving over critical water retention areas twice on each side of the silt fence, beginning with the upstream side of the silt fence.**

Sometimes, it is mandatory to go over the area twice in hard, compacted or rocky soils because the soil breaks up in chunks, and it takes repeat trips to reach the necessary compaction level.

## EASY SPLICING

When you run out of fabric in the middle of a run, you can raise the tommy® out of the soil, back up a few feet behind the installed fabric, load the tommy®, drop back into the slit next to the existing fabric, and continue on with a perfect splice. Do not splice in critical water retention areas.

## SUPPORT POSTS

Contractors use all types of posts, from steel t-posts to 1 inch sq. hardwood posts. Steel t-posts cost more, but are very sturdy when deep enough, can be spaced as needed, and can be recycled. Wood posts are relatively inexpensive, but are hard to drive deep enough into the soil for good support, and present somewhat of a safety problem for labor when driven with a heavy hammer.

## INSTALLATION WITH A SKID-LOADER

Installation is basically the same as with a tractor, except the operator has much greater control of the process. The tommy<sup>®</sup> is pulled by a tractor and basically floats through the soil. The skid-loader has the capability for downward pressure and thus the potential for very bad and very good results.

A skid-loader must have tracks and at least 60 H.P. in nearly all situations because the requirement for traction and torque are so great.

A skid-loader works great for ditch checks because the cylinders give it a large range of motion for different slopes. In cases where a skid-loader can not retract enough for the tommy<sup>®</sup> to install in a head-on slope, an adapter plate engineered as shown is recommended to facilitate those situations. **See Fig. 6 below.**

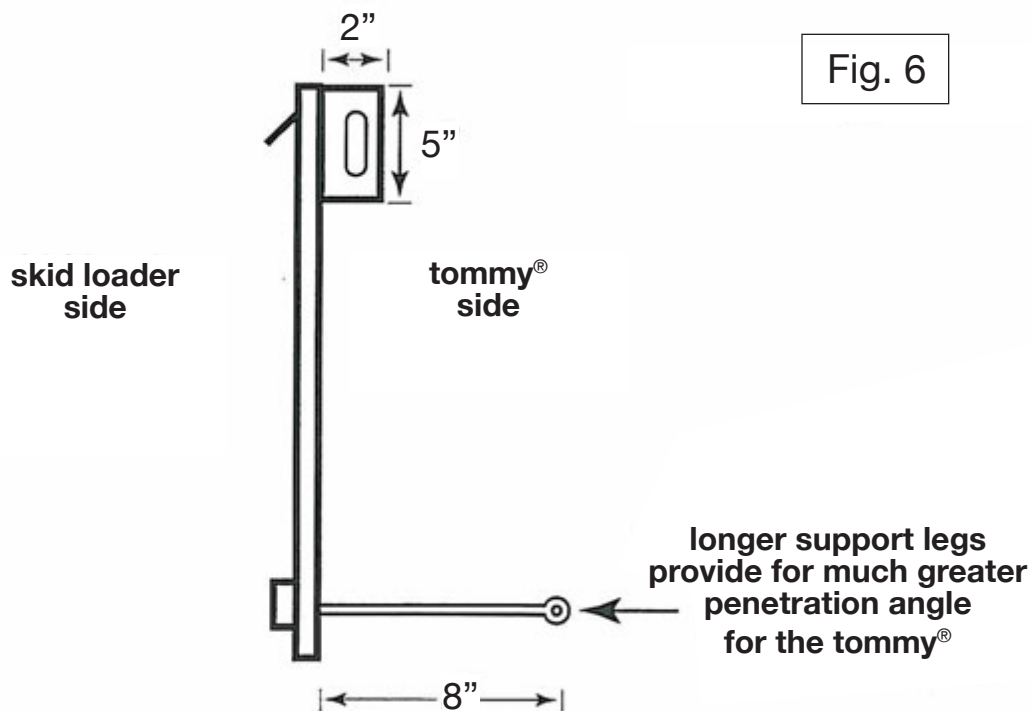

## A SUPPORT PERSON

We have found that you waste less fabric and have better control over the operation if you utilized a second person. The support person can position and hold the silt fence to get it started in the slit, walk along the tommy®, watching for proper depth, removing debris that comes up, and watching/managing the fabric flow through the machine to minimize snagging and the potential for fabric sliding off of the wheel.

## SILT FENCE PULLING OFF OF THE WHEEL

This usually happens when the operator allows the tommy® to float up, or the wheel is not operating at the bottom of the slit. If the support person is walking along and managing the 6” flap of fabric so it stays consistent on the wheel, the tommy® should do an excellent installation.

When the fabric comes off of the wheel in the middle of a run, you can either cut the fabric and splice it the same as an end of roll splice, or you can back up, rethread the fabric onto the wheel, drop the tommy® back into the slit, and proceed hoping to maintain a good installation– it may take a couple of practice runs to get the process down.

*If you have continuous problems with the silt fence sliding off of the wheel:*

- Check that the roll is free and not in a bind of some kind.
- Check that the roll is up against the arm so you are maintaining a full 6” flap on the inside of the wheel.
- Check for debris or something snagging the fabric between the panels.

## PROPER DITCH CHECK OPERATION

The tommy<sup>®</sup> frame should stay parallel with the ground under it and then be adjusted with the top cylinder as the blade and wheel go through the toe of the slope or the crest of a ditch. The operator must watch both of these critical areas while installing ditch checks or going through slight valleys. **The lower arms should be released to the completely down position so the tommy<sup>®</sup> continues to pull itself into the soil.** The top cylinder should be managed so the wheel stays at the bottom of the slit. **See Fig. 11 below.**

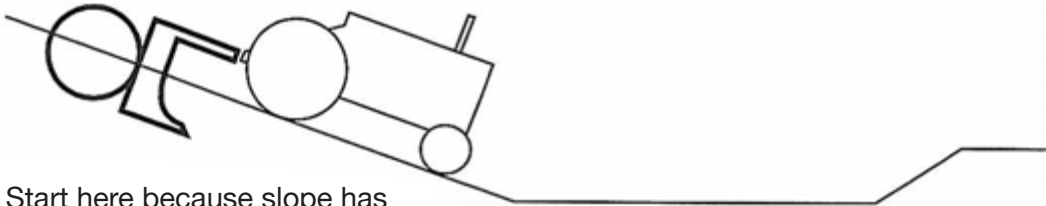

Fig. 11

stay parallel until wheel passes through target area

## INSTALLING DITCH CHECKS

When installing ditch checks, survey the slopes and choose the slope with the most consistent length of slope to start installation, even if it is the greater slope of the two. In other words, try to start the installation with the tommy<sup>®</sup> on the same plane as the tractor. **See Fig. 8 below.**



Start here because slope has the most consistent length of slope which allows the tractor to get the tommy<sup>®</sup> started easier and better.

Fig. 8

When going over the crest of a ditch, as the tractor front end levels out, the tommy® on the rear of the tractor will automatically come up, thus raising the soil disrupter and wheel out of the slit. The hydraulic cylinder offsets this reaction to a point, but it isn't always enough compensation, so it is best to plan your installation process with this restriction in mind.

**See Fig. 9 below.**

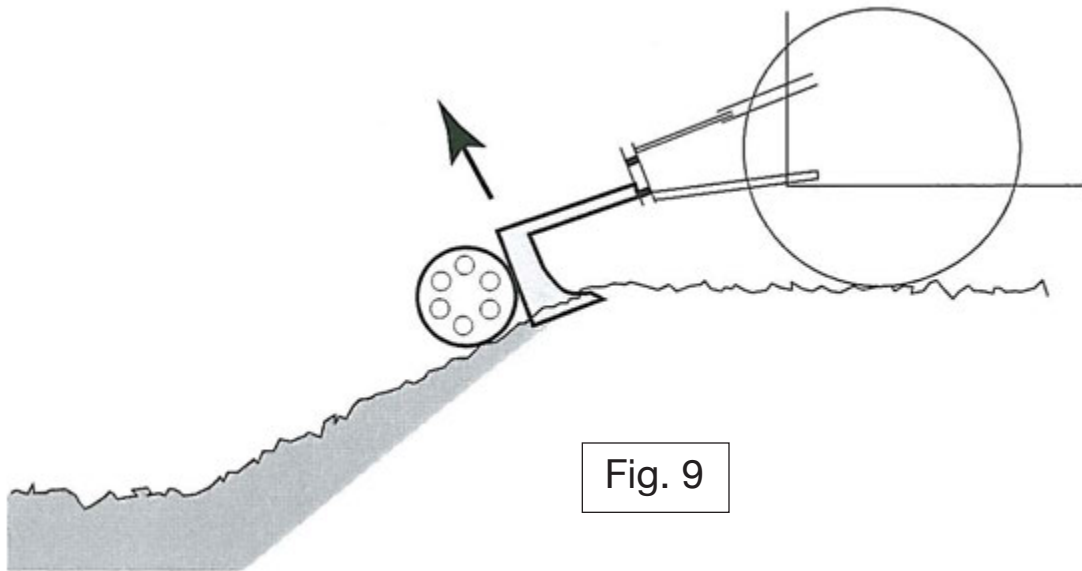

Fig. 9

When going through the toe of a slope, especially 2.5 to 1, or greater, the tractor and tommy® acting as a unit may bridge the toe of the slope and cause the soil disrupter to come out of the ground. A skid-loader may be a solution here, or you may just have to dig the silt fence in manually. **See Fig. 10.**

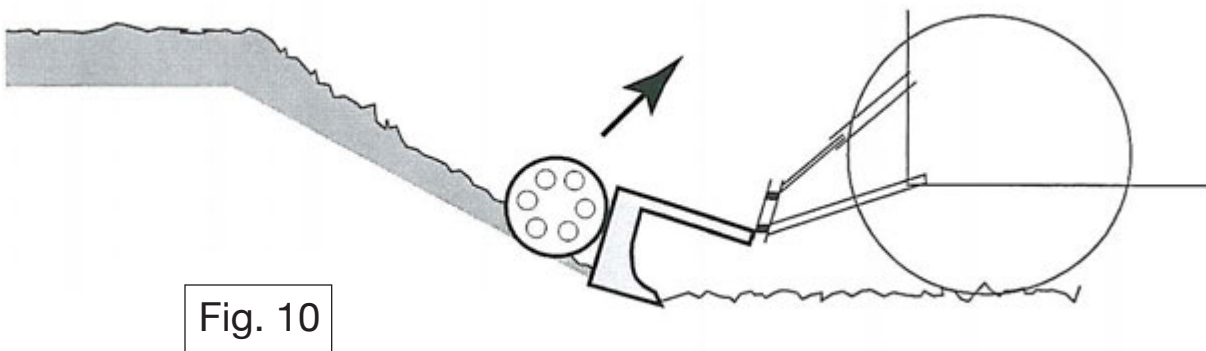

Fig. 10

There is a catch-22 here, where the longer you make the cylinder for one situation, the less it will retract for another situation. A happy medium is our goal.



## FIX DEEP RUTS

And, as with the crest of a slope, coming out of a gully rut can cause the rear of the tractor to rise and raise the tommy<sup>®</sup> out of the soil, hindering the quality of your installation.

If there is an established gully 6" deep or deeper, we recommend opening the area with your loader so the tommy<sup>®</sup> can install the fabric at the proper depth below the soil level.

**See Fig. 12 below.**

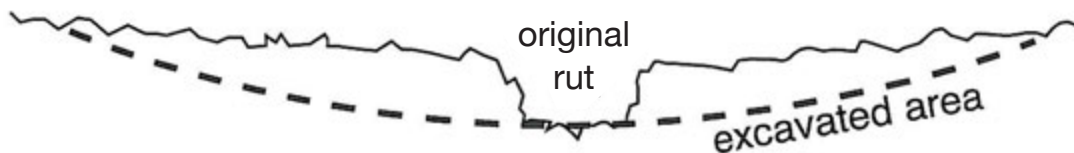

Fig. 12

Clean out gully with bucket before starting installation.

## DITCHES THAT WON'T WORK

Thin bottom ditches with steep sides are very difficult or unworkable for the tommy<sup>®</sup> when attached to a tractor because the length of the machinery just won't fit into the bottom of the ditch. We can't define a width or slope because construction situations differ greatly and it will just come with experience as to what will and won't work. **See Fig.**

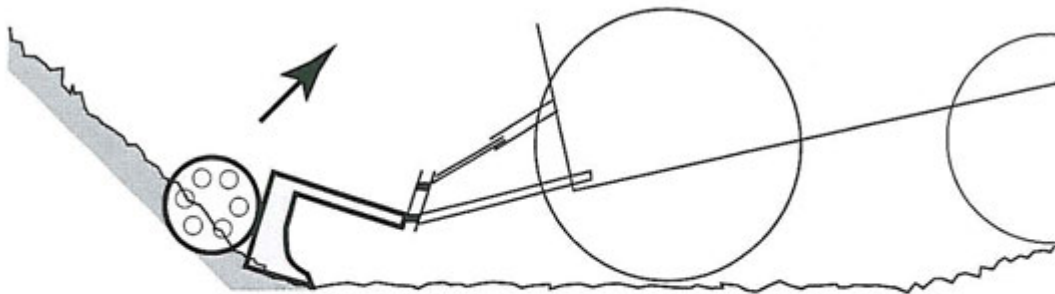

Fig. 13

Length of tractor and tommy<sup>®</sup> won't bridge bottom of ditch, which results in wheel pushing soil disrupter out of soil.

## ADVERSE CONDITIONS

The tommy® works extremely well in sticky mud and very wet soil like wetlands, but you may have to pull the tractor and tommy® through with another source of power from dry or stable ground. You can definitely install silt fence with the tommy® where you can't with any other machine.

The same is true for steep side slopes. When you lose traction on the high side wheel, you can pull the tommy® through with another power source which holds the front end of the tractor from sliding down the hill and gives you traction for finishing the job—**again installing where no other machine can operate!**

In hard, compacted ground, you may have to manipulate the machine more than usual by using the lower arms of the 3-point to vary the depth vertically 2-3" in the soil. This reduces the resistance to the soil disrupter in the soil and allows the tommy® to continue with a proper installation.

In nearly all conditions, we recommend 300 pounds additional weight on the machine. In extremely compacted conditions, in rocky soils, add another 100-150 pounds onto the tommy® weight bracket to help it into the ground. In rocky soils the coulter can inadvertently act as a wheel, and hold the tommy® up, restricting penetration. We recommend removing the coulter completely in these situations.

In very trashy soils, or in a grubbed area full of roots, you may have to drag the tommy® through the area at the penetration angle to break up the soil, and then return and install the silt fence in the created slit. In this case, you would definitely want to double or triple compact the disrupted soil around and against the silt fence fabric.

On dips, curves, and turns we recommend the support person walking directly behind and on the disturbed soil to help secure the fabric immediately until final compaction is accomplished.

Plan which direction you are going to install silt fence so the tractor doesn't end up dead headed into an area which will cause extra hand work.

If the silt fence partially comes up out of the slit in the soil, sometimes you can tuck it back in with a spade without having to reinstall it.

# ASTM D-6462-03 2003

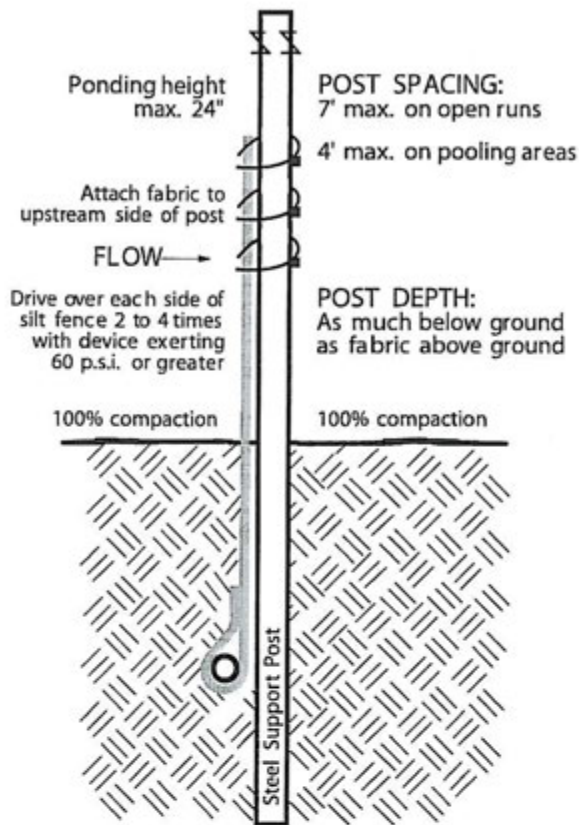

No more than 24" of a 36" fabric is allowed above ground.

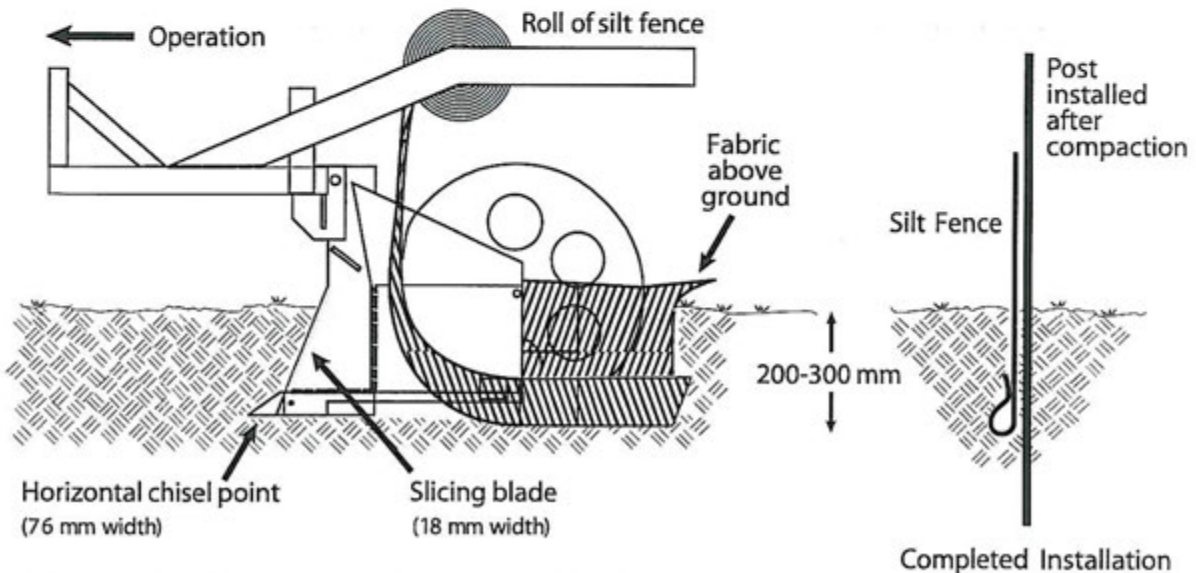
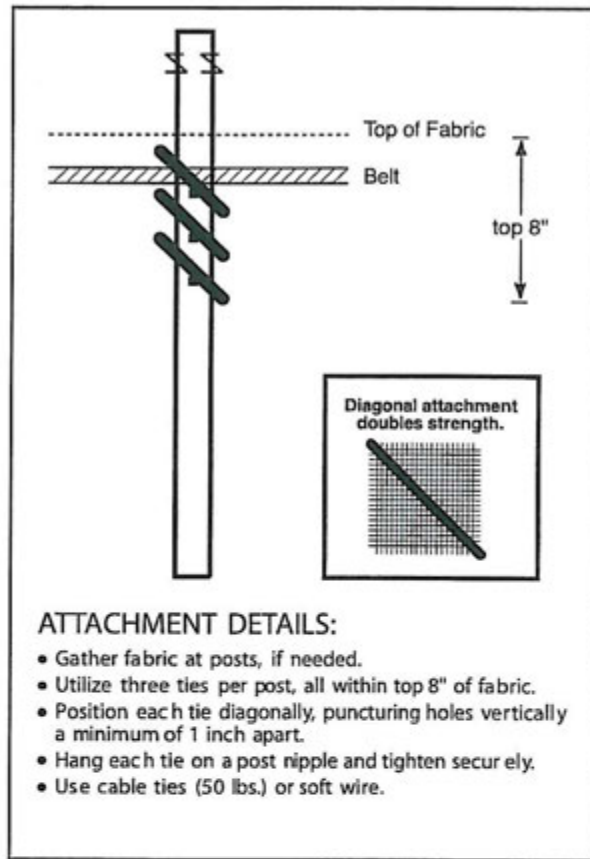

Vibratory plow is not acceptable because of horizontal compaction

## Specification Details

1. The base of both end posts must be at least 2-4" above the top of the silt fence fabric on the middle posts for ditch checks to drain properly. Use a hand level or string level, if necessary, to mark base points before installation.
2. Install posts 3-4ft apart in critical water retention areas and 6-7ft apart on standard applications.
3. Install posts 24 inches deep on the downstream side of the silt fence, and as close as possible to the fabric, enabling posts to support the fabric from upstream water pressure.
4. Install posts with the nipples facing away from the silt fence fabric.
5. Attach the fabric to each post with three ties, all spaced within the top 8" of the fabric. Attach each tie diagonally 45 degrees through the fabric, with each puncture at least 1" vertically apart. Also, each tie should be positioned to hang on a post nipple when tightened to prevent sagging.
6. Wrap approximately 6 inches of fabric around the end posts and secure with 3 ties.
7. No more than 24" of a 36" fabric is allowed above ground level.
8. The installation should be checked and corrected for any deviations before compaction. Use a flat-bladed shovel to tuck fabric deeper into the slit if necessary.
9. Compaction is vitally important for effective results. Compact the soil immediately next to the silt fence fabric with the front wheel of the tractor, skid steer, or roller exerting at least 60 pounds per sq. inch. Compact the upstream side first, and then each side twice for a total of four trips.

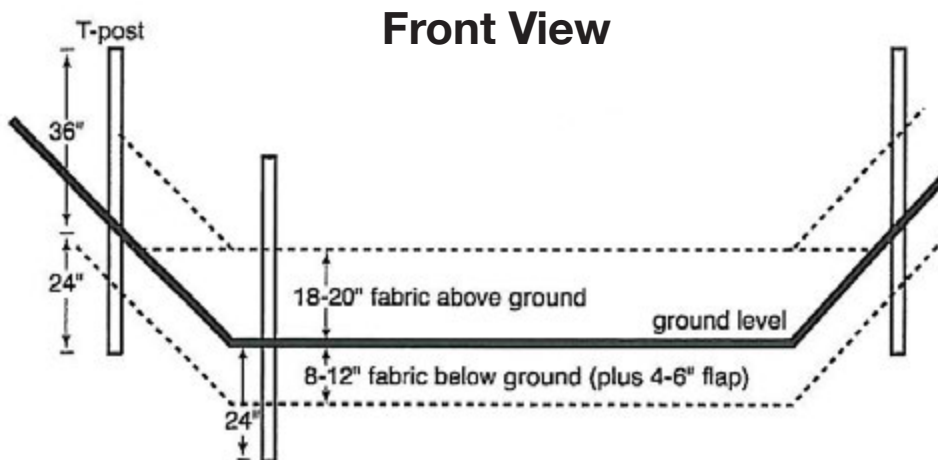

The base of both end posts must be 2-4" above the fabric on the middle posts for the silt fence to properly drain. Use string level when necessary

Silt Fence That Works

# TRADITIONAL Trenching Method

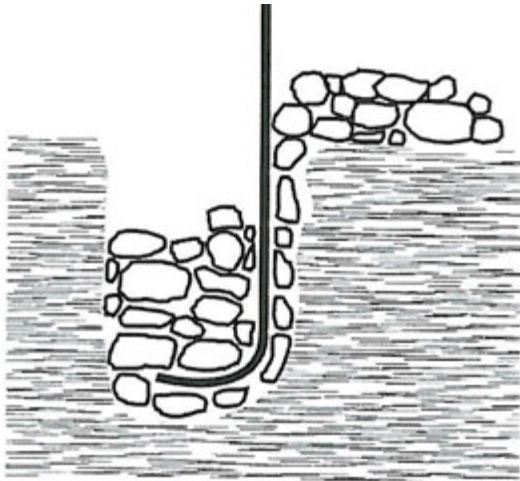

Half the backfill is unavailable.  
Washouts are common and confirmed by EPA Research.

## ASTM D-6462-03 Updated trenching specification 2003

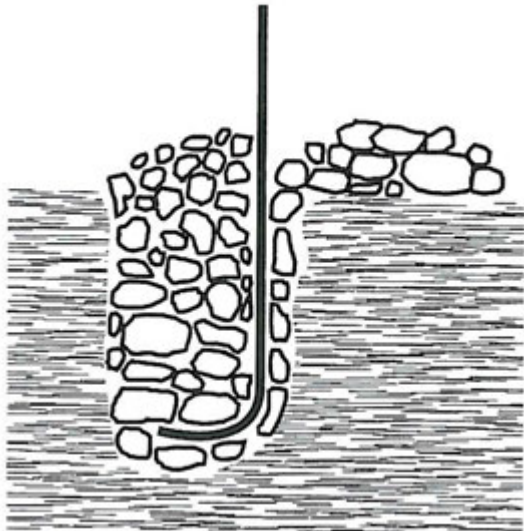

Requires over-backfill of trench prior to mechanical compaction.

*"The problem is—where to get the additional backfill?"*

## ASTM D-6462-03 Updated trenching specification 2003

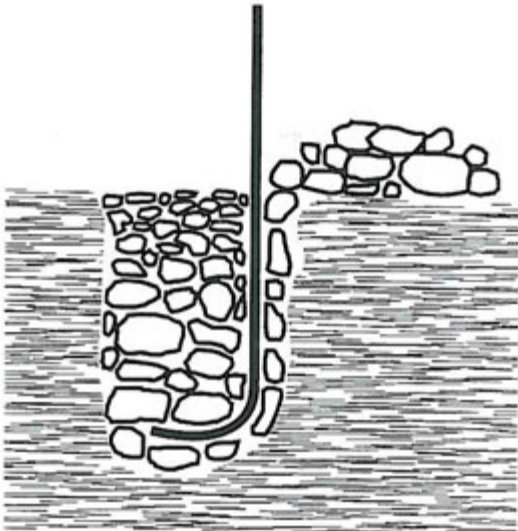

Compacted backfill must be level with undisturbed soil.

## ATTACHMENT TO STEEL T-POSTS

- Triple tie silt fence to the post within the top 8 inches
- Position the post with the nipples facing away from the fabric
- Attach the silt fence to the support post with three ties (either 16 gauge wire, or 50 lb. cable ties - which you will need to snip to a point)
- Position each tie diagonally through the fabric with each puncture hole at least 1 inch vertically apart, attaching several horizontal threads for much greater strength
- Position each tie over a nipple and tighten to avoid slippage down the post

*(Hint: Kneel on the post side of the fabric, puncture 1 inch below the desired post nipple and push tie through. Come back through the fabric slightly above the same nipple, and securely tighten the tie above and hanging on the nipple.)*

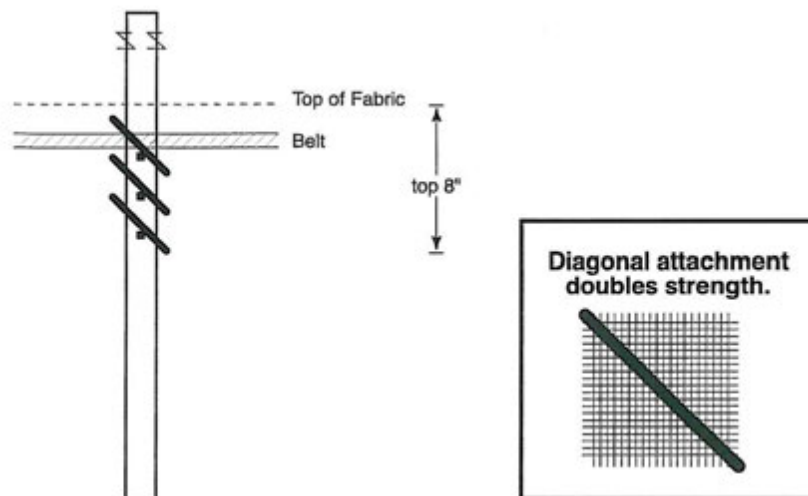

We have found that proper attachment to the support post is extremely important to the whole system. Iowa probably has the greatest problem with silt because of our fine, clay soils and heavy rainfalls (both per storm and annually). We have seen the cheapest woven silt fence fill up and hold silt when attached properly to appropriately spaced support posts. In addition, silt fence attached with three ties have weathered two Iowa summers and one winter with virtually no failures regarding ties.

## WOVEN-WIRE FENCES

One tie is completely inadequate, and is the cause of many silt fence failures commonly thought to be from lack of horizontal structure, thus leading to designs involving wire fencing as a backing for silt fence. Wire-backing is extremely expensive, creates a tremendous disposal/environmental problem, and in most cases makes little sense because today's materials, when supported and attached properly, will handle the potential load. Often times, additional height for silt fence is specified with woven-wire. This also lacks good engineering design and function because the small posts specified won't support the horizontal load.

## INADEQUATE POWER

Underpower, underweight, and undertraction each significantly reduces efficiency, and possibly effectiveness, under many conditions. Each factor may cause the operator to raise the tommy® partially out of proper operating depth to enable the tommy® to proceed in difficult situations, thus potentially reducing its effectiveness. Underweight may also require the use of a compacting device other than your tractor.

## TRACTOR RECOMMENDATIONS

- 4-wheel drive makes turning and operating around construction sites much more efficient, as well as providing extra traction on slopes and in compacted soils.
- A loader provides opportunity to level out piles or large chunks of soil in your way, a loader can fix gullies and washouts prior to installation, and a loader can carry 500-800 pounds for improved compaction capability
- A 30+ HP, 3000 lb. gear-drive tractor is recommended because it takes quite a bit of torque and traction in compacted soils to achieve effective and efficient results
- We feel having a 16-18 inch height at the base of the lower arms of the 3-point is optimum.

**THE tommy® IS ALSO AVAILABLE IN A TRAILER VERSION  
FOR PULLING FROM A DRAW BAR.**

# OFFSET DETAIL

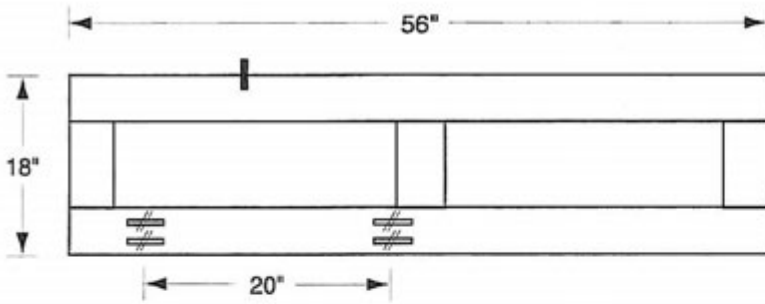

REAR VIEW  
(As attaches to Tommy)

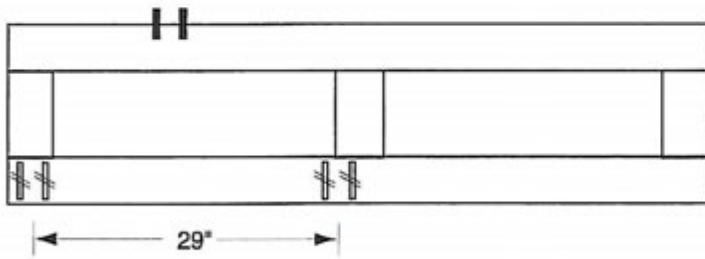

FRONT VIEW  
(As attaches to Tommy)

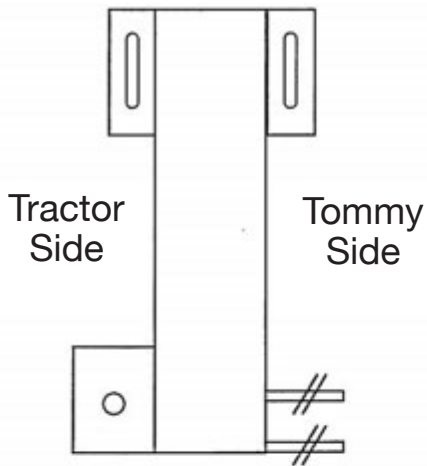

END VIEW

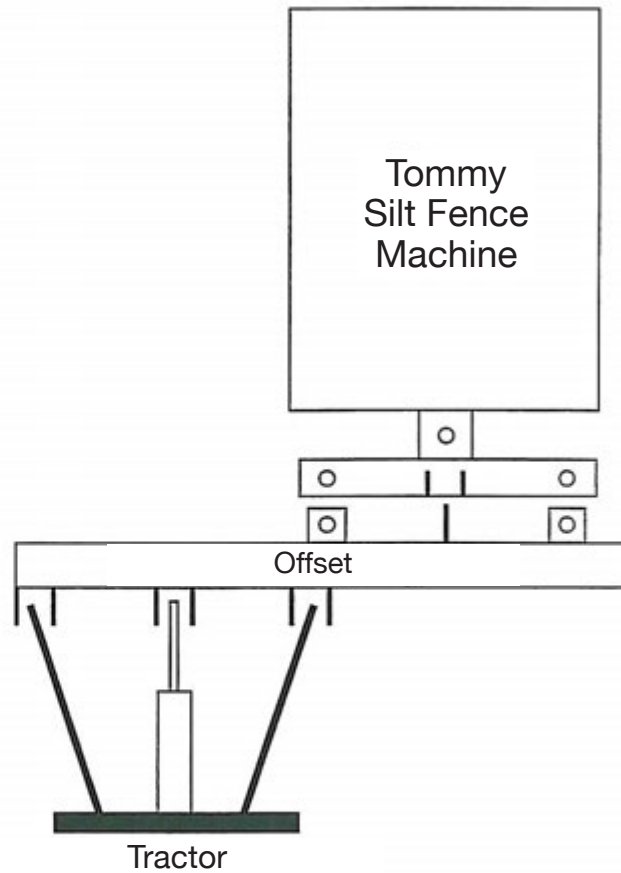

All Framework  
4 x 6 x 3/8" Tubing



## HYDRAULIC CONSIDERATIONS

- The tommy® comes with a hydraulic cylinder because it is nearly mandatory for quality operation. The cylinder lets you follow the terrain, allows you to install most ditch checks, and reduces fabric waste tremendously by getting the tommy® into the soil as soon as possible.

On tractors with a loader, but no other hydraulic outlets, you can utilize the loader system without disengaging the loader. It requires installing electric solenoids (three-way valves) into one pair of lines controlled by the loader joy stick. The electric solenoids allow you to divert the direction of hydraulic oil from the loader to the tommy® cylinder, and still utilize the joy stick to control either operation. We use an electric switch attached directly to the joy stick (one normally used on a truck as the switch for the two-speed axle) so the operator can easily switch from one operation to the other.

**See Fig. 15 below.**

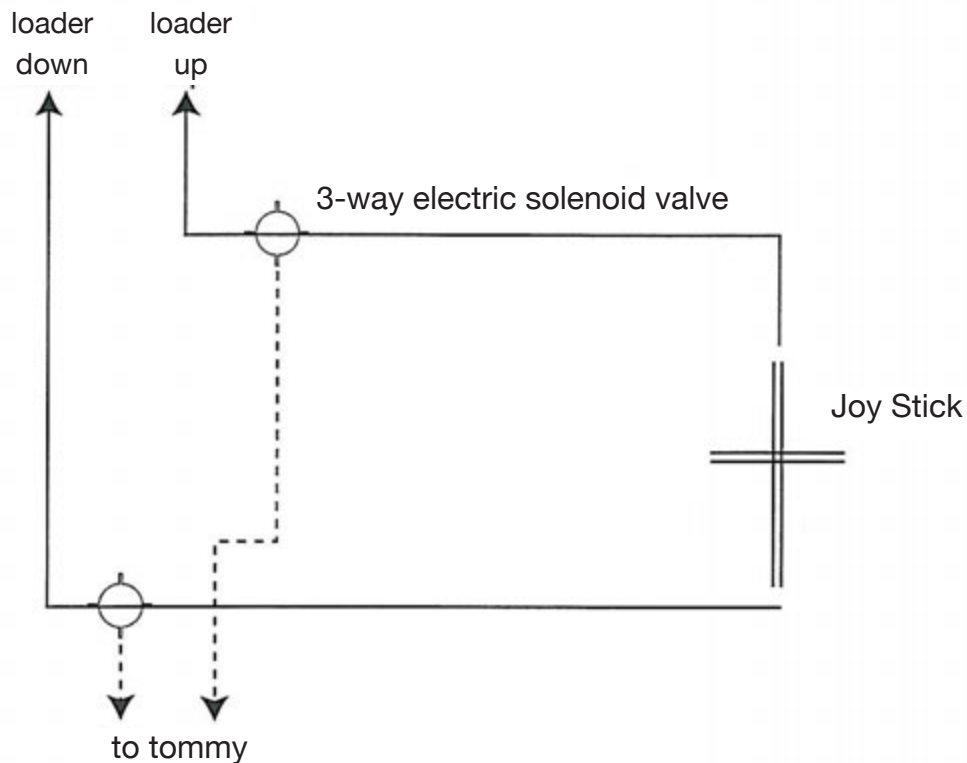
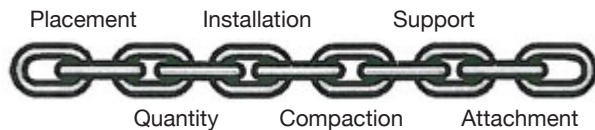

Fig. 15

## SILT FENCE THAT WORKS

### Effective silt fence works like a chain ...



**Each link must work;  
if one link fails, the system fails**

**Silt fence is not a simple,  
'anyone can do it' BMP.  
It requires knowledge  
and effort to  
achieve efficacy.**

### On-site adjustment is mandatory

Actual site grades are often different than those shown on a SWPPP.

Contractor must communicate with designer and operational manager to adjust for as built conditions.

### Two most common problems

- Placement issues - won't pond water or insufficient quantity for the proposed control area
- Installation issues - inadequate backfill and/or compaction

### Every silt fence should create a storage area for ponding.

- Do not install if can not create storage .
- Do not install in a V-shaped or narrow channel. Use erosion control blankets.
- Do not install in a straight line where runoff can flow around an end.
- Install on the contour to control velocity



Properly installed silt fence detains water for sedimentation to occur

## Silt Fence Placement

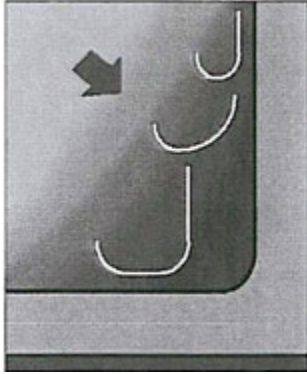

Designs called J-hooks insure water & sediment pond behind each silt fence.

## Stop sediment before it reaches the pavement.

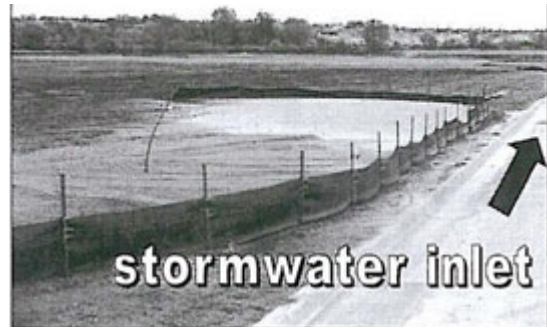

## Install upstream of outlet



Do not install in continuous flow

## Prevent overland water from eroding the slope face



Leave room for sediment storage at toe of slope

## Protect area intakes with larger silt fence structures, if possible

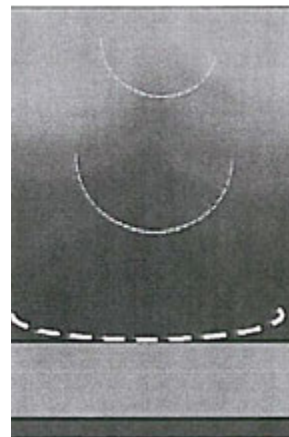

Large areas need additional runs installed in the interior to reduce the volume and velocity of runoff.

- 5000 sq. ft. is probably a manageable control area for a silt fence smile -about the size of a residential lot
- Maximum slope length above a silt fence - 100 linear feet

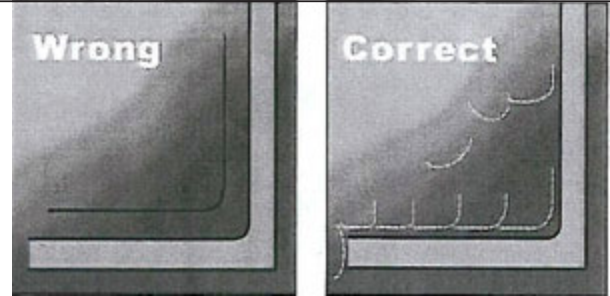

**No runs longer than 200 ft.**  
 Separate area into multiple storage areas.  
 \* Today's Requirements \*

**EPA co-sponsored research has shown compaction is the critical factor in silt fence effectiveness.**

**Poor compaction = washouts**



**Overfill and compact trench to at least 50% of the in situ soil**

ASTM D-6462-03  
 Updated trenching specification 2003

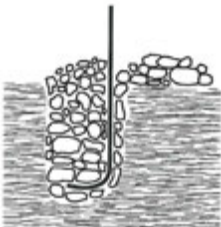

Requires over-backfill of trench prior to mechanical compaction.  
 "The problem is--where to get the additional backfill?"

ASTM D-6462-03  
 Updated trenching specification 2003

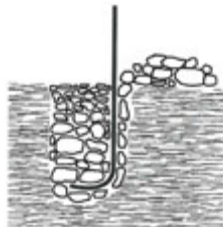

Compacted backfill must be level with undisturbed soil.

**Achieve consistent installation and compaction**

Static Slicing



During Insertion - Disrupted Soil



After Compaction - No Washouts

## Proper installation



## Support Post Spacing

Post should be paced a maximum of 6 ft. apart and driven 24 inches into compacted ground.

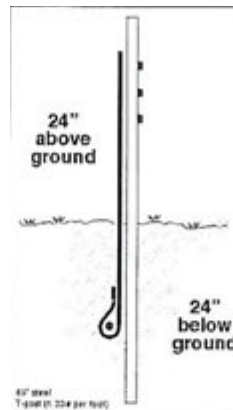

## Attachment

- **Steel posts—3 ties per post in the top 8 inches of the fence, each tie hung on a post nipple, and placed diagonally.**
- **For wood posts, several staples per post overlaid with a lath.**

## Maintenance

- **Structural type—falling down**
- **Performance type**
  - \* **Blown out**
  - \* **At capacity**
- **Replace when full, do not remove sediment**

## Inspector Responsibilities

- **Inspectors must know proper placement and installation concepts.**
- **Must not approve improper installations for payment.**
- **Is not concerned with budgeted quantities.**

## Tell-tale signs of effectiveness problems.

- **Lack of sediment retention**
- **Lack of ponding after a rain even**
- **Solution: Inspector must look for a blowout and require replacement**



**Quote Requested by:**

name .....

company .....

phone # .....

date requested: .....

e-mail quote to: .....

Comp.	Part #	POINT	# pcs. Ordered	Price \$ / piece	Total \$ / part
<b>Plow Shank</b>	TMR-24	Plow Point			
	TMR-1019	Removable Wing			
	TMR-1030	Side Shield Retainer			
	TMR-3019 FW	Fabric Wheel			
	TMR-3019 AX	Fabric Wheel Axle Assy.			
	TMR-1201921	Plow Shank Assy.			
<b>Torsion Spring</b>	TMR-LSp101	Left Hand			
	TMR-Rsp102	Right Hand			
	TMR-1052	Spring Pivot Pin			
	TMR-1048	Spring Pivot Bushing			
	TMR-1059	Carrier Guide Keeper			
	TMR-1060	Threaded Take Up			
	TMR-1056	Carrier Take Up			
	TMR-1058	Carrier Pivot Bar			
	TMR-1024 rb	Spring Arm Roller			
<b>Coulter Assy.</b>	TMR-7800	Coulter Arm Assy.			
	TMR-78 Wcd	Coulter Disc			
	TMR-7787	Coulter Shank			
<b>Other Parts</b>	TMR-2322	L Lynch Pin			
	TMR-1029 Wt	Weights			
	TMR-1029 Wt	Weight Bracket			
	TMR-1043	Pivot Pin Cover Plate			
	TMR-4142 Rt	Fabric Roll Tensioner			
	TMR-2000	3 Pt. Step Pin			
	TMR-5657 hydc	Hydraulic Cylinder			
	TMR-1045	Front Outrigger			
	TMR-2322	Rear Support Leg			
	TMR-0044 FbK	Fabric Knife			

**TOTAL Order** \$





SILT FENCE MACHINE

Devon Distributing Corporation

3718 SW Court Ave • Ankeny, Iowa 50023

1-800-965-4665 • 515-645-9699

info@tommy-sfm.com

name \_\_\_\_\_

company \_\_\_\_\_

shipping address (no po boxes please) \_\_\_\_\_

city \_\_\_\_\_ state \_\_\_\_\_ zip \_\_\_\_\_

phone # \_\_\_\_\_

date requested: \_\_\_\_\_ e-mail order confirmation to: \_\_\_\_\_

Part #	PART	OTHER	# pcs. Ordered	Price \$ / piece	Total \$ / part
10	SKID LOADER ADAPTER PLATE	150 LBS		\$450.00	
11	WHEEL	2"X24X24"/6LBS		\$165.00	
12	1/2" FLANGED BUSHING/BOLT	1 LBS		\$5.00 EA	
13	HARDENED STEEL POINT	5 LBS		\$100.00	
14	FABRIC KNIFE	1 LB		\$25.00	
15	PRESSURE PLATE & SPRING ASSY	9 LBS		\$150.00	
16	HINGED WING	10 LBS		\$125.00	
17	8" STROKE HYDRAULIC CYLINDER	36X4X4/22LBS		\$310.00	
18	WING CLAMP	3 LBS		\$90.00	
19	12" OFFSET ASSEMBLY	SHIP TRUCK		\$975.00	
20	WEIGHTS - 75LBS EACH	150 LBS		\$400.00	
21	COULTER ASSEMBLY	26 LBS		\$300.00	
22	COULTER SUPPORT POST	10 LBS		\$50.00	
23	COULTER DISC ONLY	12 LBS		\$90.00	
24	COMPLETE KNIFE ASSY(RTN ORIG)	SHIP TRUCK		\$1,950.00	
25	FRONT PLATE			\$400.00	
26	COULTER COLLAR			\$25.00	
27	SILT FENCE THAT WORKS MANUAL			\$24.95	
28	INNER BEARING PKG	2 LBS		\$50.00	
29	400 MEASURING WHEEL	400 MEASURING WHEEL		\$127.50	

**TOTAL Order \$**

**Patent Technology Rights:** The "tommy" silt fence machine and the installation process are patented under the United States Letters Patent number 5,915,878. Carpenter Erosion Control owns this patent which protects against the construction, use, or sale of a silt fence machine infringing on the patented process.

It is illegal and an infringement to patent rights to build a machine using this process, even for your own use and not for sale to others. Over \$1 million has been invested in bringing this exceptional technology to our industry.

Devon Distributing offers rewards of up to \$5,000.00 for confidential information leading to payments by an infringer to Carpenter for the construction, use, or sale of a silt fence machine.

The **tommy** can carry approx. 3,000 LF of STD weight silt fence material. One of the most economical ways to purchase rolls of silt fence is to purchase partial master rolls to avoid re-rolling charges. (Partial master rolls are obtained from manufactures of pre-fabricated silt fence or possible your local distributor.) All prices are subject to change without notice. Please call our office for current pricing.

